

# FutMon Kick-Off Meeting Hamburg 14.01.2009

Presentation Thomas Mayer on:

- The External Monitoring Team
- Roles of Project Participants
- Information and Transparency
- Partner Agreements

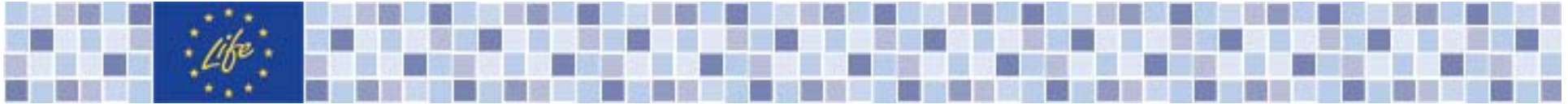



# The External Monitoring Team



*FutMon Kickoff, Hamburg, 14 Jan 09*

*Thomas MAYER, Monitoring Team*

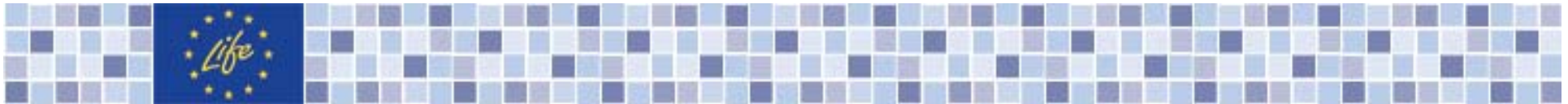

## External Monitoring

is contracted by the EC to the consortium

Astrale GEIE which consists of partner companies all over Europe.

### **Particip** GmbH in Freiburg

(D) is one of these companies monitoring projects in Germany and Austria

[www.astrale.org](http://www.astrale.org)

[www.particip.de](http://www.particip.de)

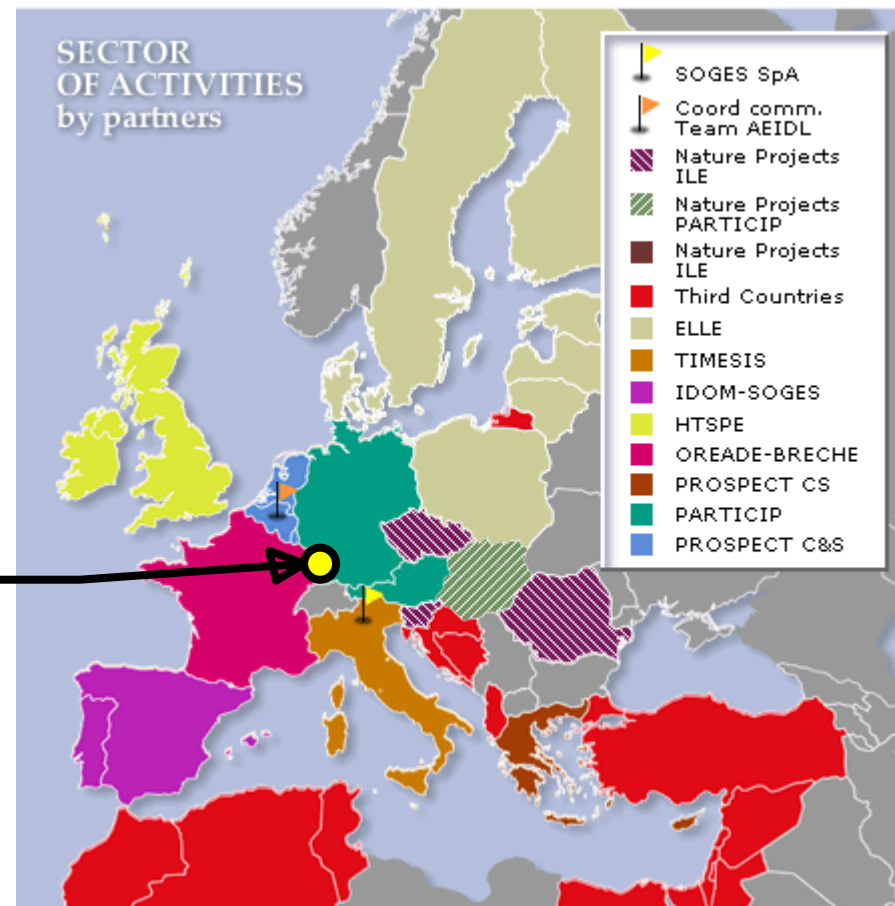

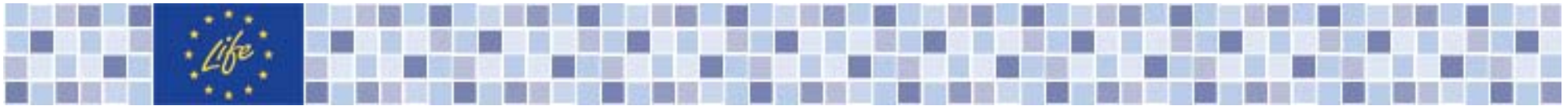

# External Monitoring Teams

## Supporting the Commission in the follow-up of the project

- Explaining rules and practices
- Not entitled to take any decision on behalf of the Commission
- Not involved in the management of the financial resources

## Helping the Commission to assess the project progress at the technical level

- Acting under confidentiality rules
- Independent from the projects



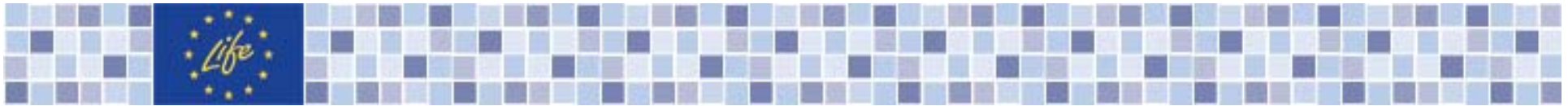

# Roles of Project Participants





# Participants in the project

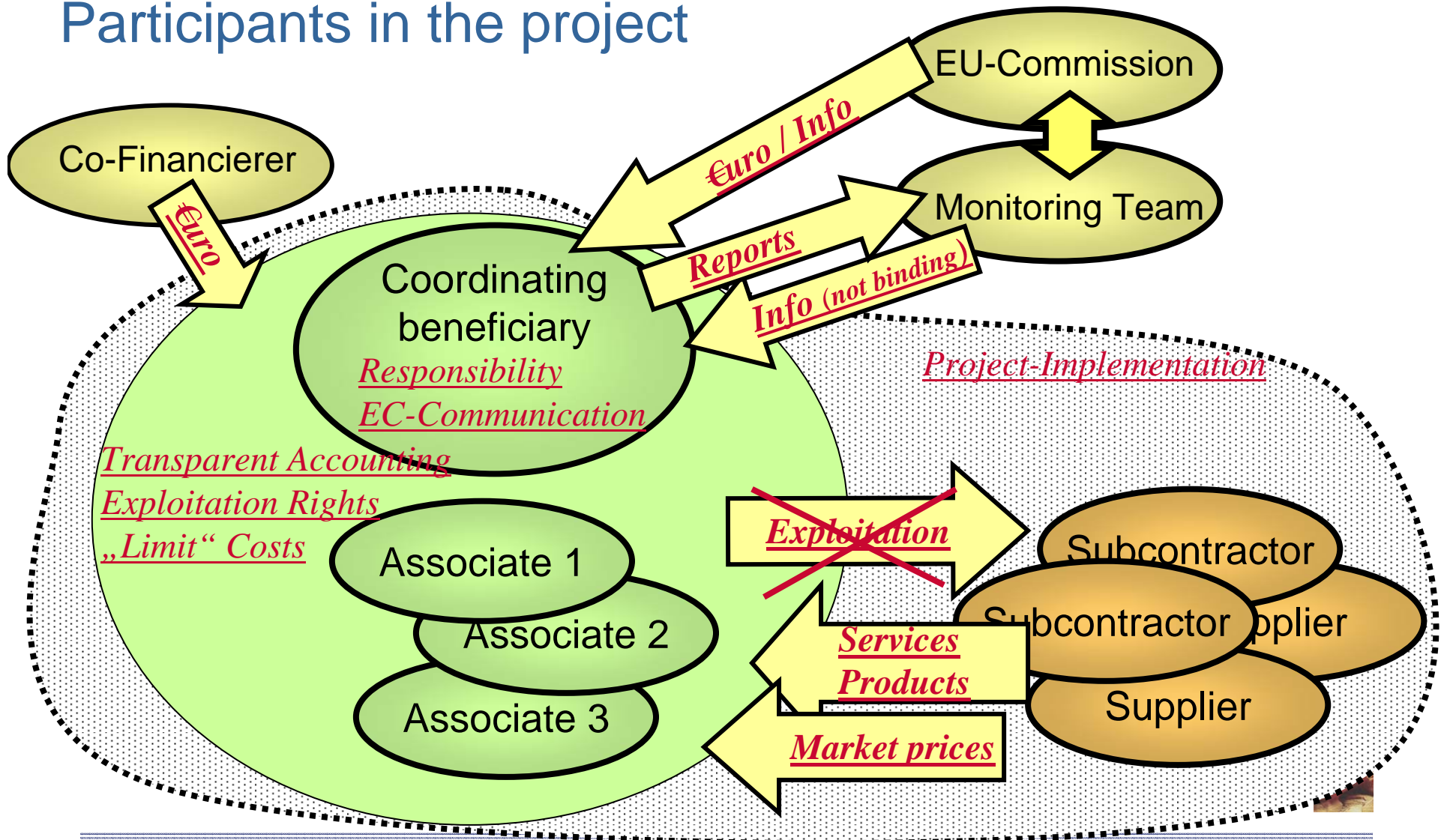

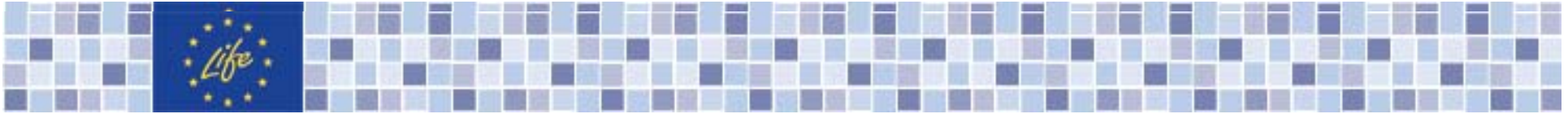

# The Coordinating Beneficiary

*(art. 4)*

- Sole legally and financially responsible to the Commission for the implementation of the project
- Concludes agreements with the associated beneficiaries within 9 months, following «Guidelines» and including the «mandate»
- Is granted power of attorney by associated beneficiaries (mandate)
- Is the single contact point for the Commission and the only one reporting directly to the Commission
- Is directly and considerably involved in the technical implementation
- Is responsible for the dissemination of the project results
- Receives the funding from the EC on his account and is responsible for the distribution of it to the associated beneficiaries



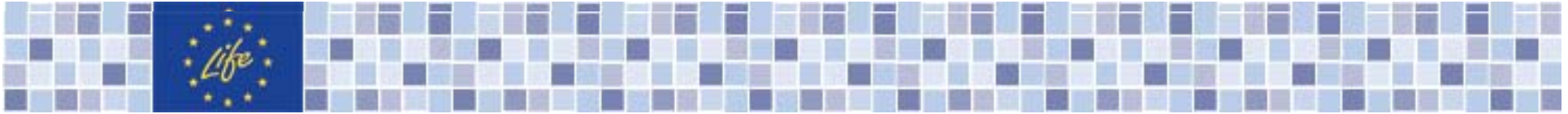

## The Associated Beneficiaries

*(art. 5)*

- Provide the coordinating beneficiary with all supporting documents necessary for technical and financial reporting
- Grant power of attorney to the coordinating beneficiary (mandate)



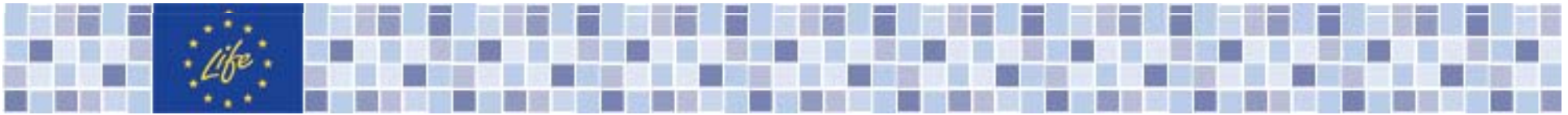

## All Beneficiaries

*(art. 6)*

- publish Community support
- freely share know-how
- only charge their direct costs (e.g. gross wages instead of market dayrates)
- are prohibited to act as subcontractors
- have a transparent accounting system (cost centers)
- provide invoices, wages and proofs of payment to coordinating beneficiary and EC
- contribute financially to the project



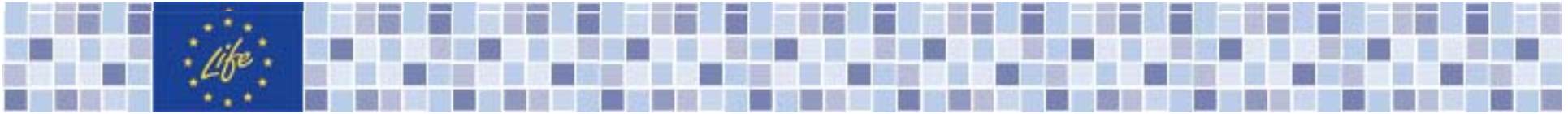

## THE CO-FINANCIERS

*(art. 7)*

- Contribute financially to the project but do not benefit from the Community contribution
- Are not directly involved in the technical implementation of the project
- All beneficiaries shall conclude with co-financiers any agreement to ensure co-funding



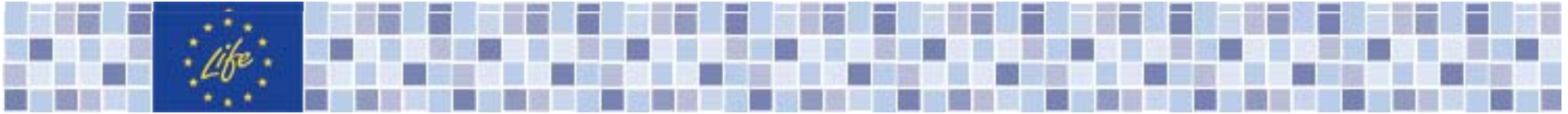

## THE SUB-CONTRACTORS

*(art. 8)*

- Provide external services to the coordinating beneficiary / associated beneficiaries and receive the corresponding full price
- Have no financial investment in the project
- Have no right on the project results
- Public tendering for Public coordinating beneficiary / Associated beneficiaries
- Private coordinating beneficiaries/Associated beneficiaries: for purchase exceeding € 125 000: Competitive tenders and bid offering best value/money



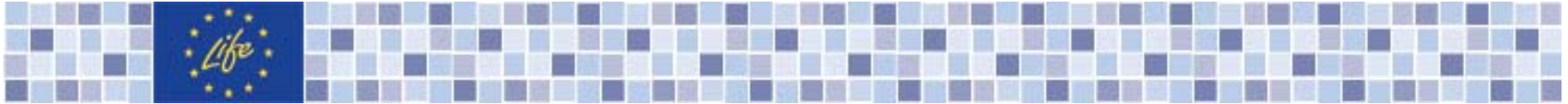

# Information for Monitoring Purposes & for the Public

## Transparency



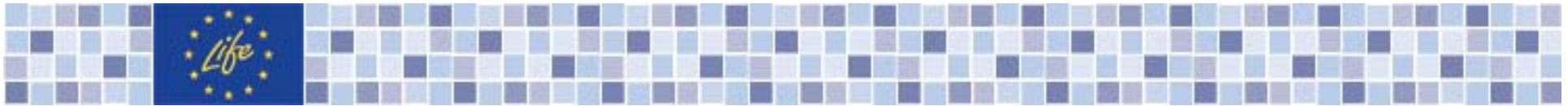

# Monitoring of the FutMon Project

FutMon is the largest LIFE project.

The EC LIFE unit must prove, that the funding of this public money follows the rules of the LIFE programme.

Therefore the EC LIFE unit wants to „see“ (and understand) what the project has done.

Monitoring and evaluation:

- Has the project reached the proposed goals and sub-goals?
- Has the project executed the proposed activities?
- Has the project reached the proposed milestones?
- Has the project submitted the proposed deliverables?



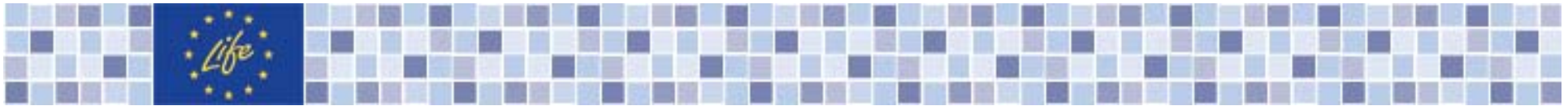

# Transparency of the Project Progress

- The External Monitoring Team suggested to describe the project and its progress into the Internet:

An interactive map of the project

- a diagramme of the tasks and their interconnections
- drill down possibility to access details
  - description (for the layman)
  - status quo before project
  - targets and sub-target
  - activities during the project
  - status after the project

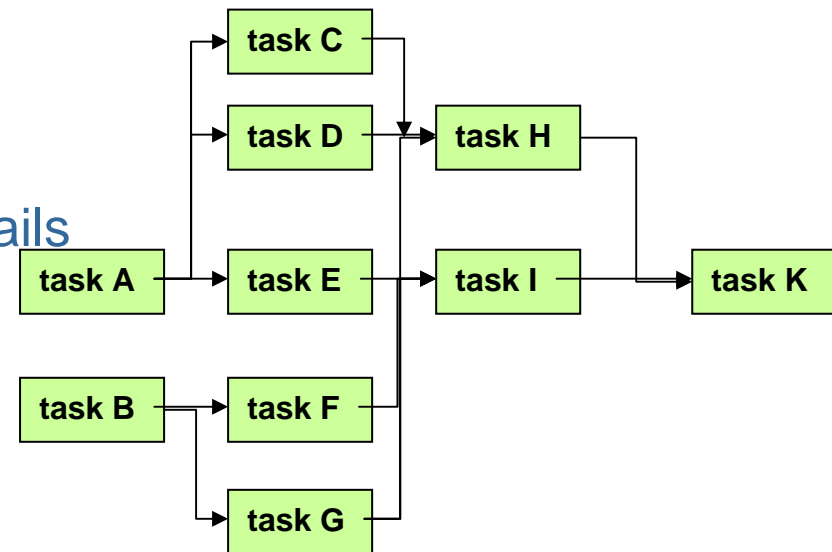

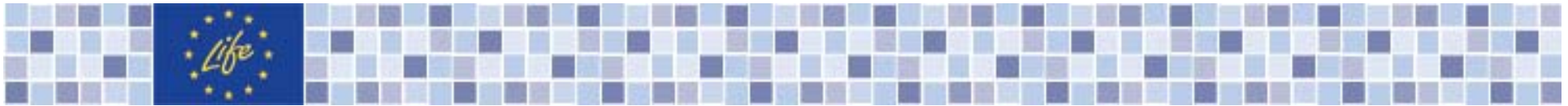

# Transparency of the Project Progress

This description of the data, modelling methods and outputs aids several purposes:

- Monitoring and evaluation
- Information for all partners
- Information for the interested public  
(a Layman Report is obligatory at the end of the project anyway)
- Management of the project

Therefore please carefully respond to the questionnaire sent to each partner last week.



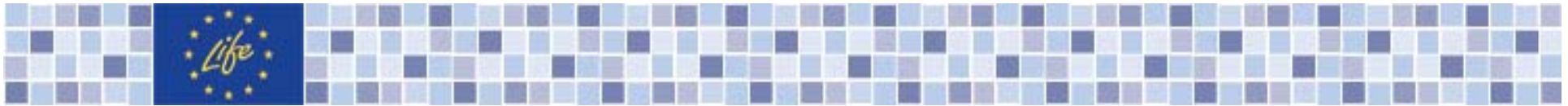

# Partner Agreements



*FutMon Kickoff, Hamburg, 14 Jan 09*

*Thomas MAYER, Monitoring Team*

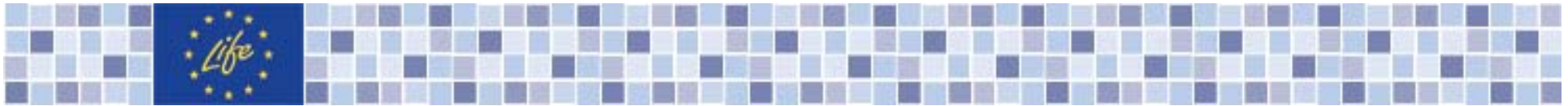

## Partner Agreements

- Find rules for the problems, not for the normal/ ideal operation.
- Payment only after submission of results and passing quality control.
- Rules for non-delivery, late delivery, low quality.
- Information and documentation obligations (e.g. proof of individual gross wages and not only categories like „BAT 2a“)
- Rules for ownership of equipment (e.g. in case of withdrawal)
- Rules for rights on results, dissemination, exploitation of results.



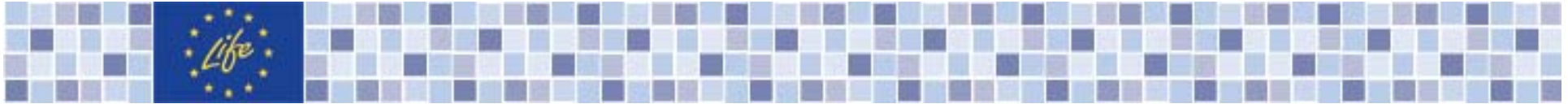

Thank you for your attention.  
Your Monitoring Team



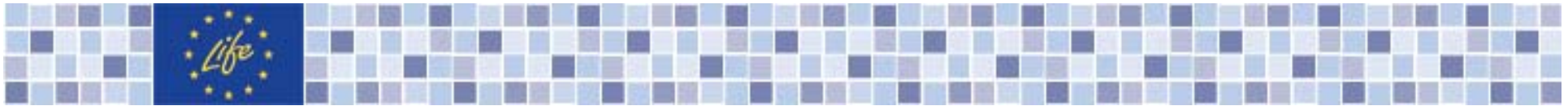

# Backup 1



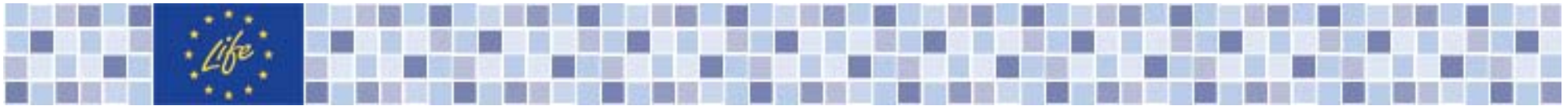

## Agenda for LIFE Administrative Session

13:40 Introduction LIFE Unit, Roles, Responsibilities

13:50 Common Provisions - Technical Issues and Reporting

14:15 Monitoring Team, Roles or Project Participants, Partner Agreement

14:30 Common Provisions – Communication

14:45 - - - - - Coffee Break - - - - -

15:00 Common Provisions - Financial Issues

15:30 Questions & Answers

16:00 End of session





# Beispiel Fördersätze pro Kategorie

Categories of expenditures	Payments made by project in €			Funding	Funding
	Real costs	% Eligible	Eligible €	€at 50% rate	% of total
1. Personnel	500.000	100%	500.000	250.000	50,0%
2. Travel	20.000	100%	20.000	10.000	50,0%
3. External assistance	200.000	100%	200.000	100.000	50,0%
4. Durable goods:	<i>for durable goods only the depreciation is eligible</i>				
Infrastructure	100.000	max 25%	25.000	12.500	12,5%
Equipment	1.000.000	max 50% hier z.B. 43%	430.000	215.000	21,5%
Prototype	100.000	max 100%	100.000	50.000	50,0%
Sub total	1.200.000		555.000	277.500	23,1%
5. Consumables	10.000	100%	10.000	5.000	50,0%
6. Other costs	10.000	100%	10.000	5.000	50,0%
7. Overheads	135.800	100%	135.800	67.900	50,0%
<b>TOTAL</b>	2.075.800	6	1.430.800	715.400	34,5%





# Beispiel Ausrüstungsgüter

4.2 Equipment	Real Cost	deprecia tion in %	{4} Eligible Cost
Ausstattung Schaltwarte	€ 7.184,59	19%	€ 1.397,00
PC Anlage	€ 31.276,13	85%	€ 26.584,71
Protool Rührwerk	€ 173,63	16%	€ 27,97
Antika Mischer	€ 338,53	78%	€ 263,30
Mikrowellenanlage	€ 9.900,00	100%	€ 9.900,00
Mikrowellenanlage LK19 2	€ 89.100,00	27%	€ 24.057,00
Silo Technik	€ 12.164,56	100%	€ 12.164,56
Regus Sandsilo Piletrucks	€ 989,00	17%	€ 171,17
Silo Pileanlage	€ 1.830,70	69%	€ 1.271,32
Heißluft für Jet-Trockner	€ 30.400,00	17%	€ 5.066,67
Sandrockner	€ 526,86	17%	€ 87,81
Heißluft für Jet-Trockner	€ 6.135,14	17%	€ 1.022,52
Luftmengeänderer undrockner	€ 666,45	6%	€ 40,39
Konischer-Titration	€ 15.531,50	24%	€ 3.721,09
Thermoöl-WT	€ 3.677,10	79%	€ 2.911,04
Sonder-Ölventile für NTK-Einsatz	€ 4.476,10	79%	€ 3.543,58
Öl-Brenner-Komponenten	€ 743,40	100%	€ 743,40
<b>TOTAL</b>	<b>€ 215.113,69</b>	<b>43%</b>	<b>€ 92.973,54</b>

**Nur tatsächliche  
Abschreibung  
während Projekt  
zählt !!!  
Bei Equipment  
Deckel bei 50%**



ing Team

(max 50% eligible)

